

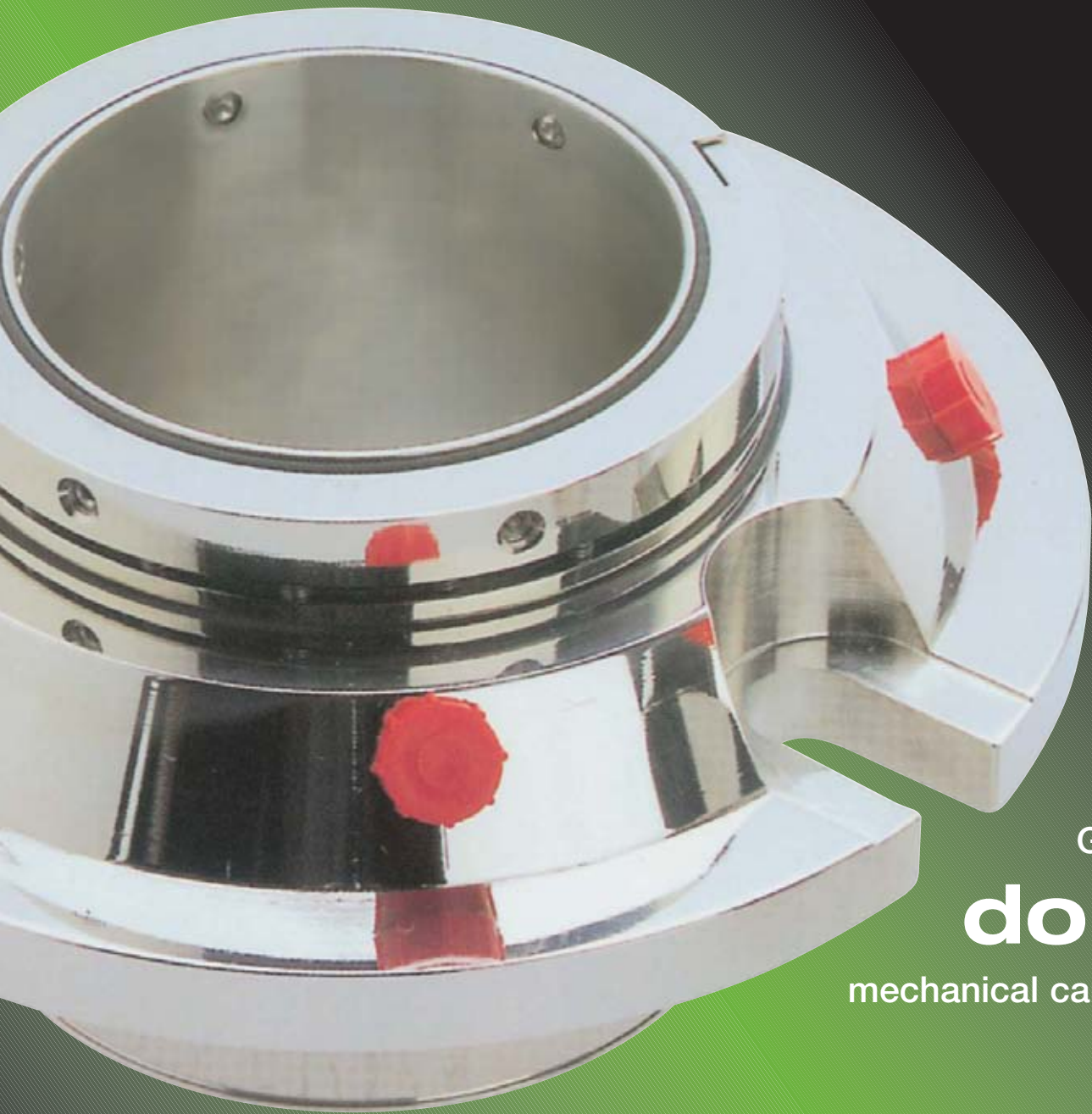

GLE range of
double
environmental
cartridge mechanical seals
302™ series



GLE range of
double
mechanical cartridge seals

To conform to current environmental legislation double cartridge seals are specified to provide maximum emission control in critical and noxious applications.

The double balanced cartridge seal design uses 50% of the power required by standard unbalanced seals and only 20% of the power required by pump packing.

All packing must leak to survive, whereas seals should be leak free. This reduces both environmental contaminants and disposal costs.

The 302 is a face-to-face double cartridge seal that has been designed for noxious and difficult to seal applications in Chemical and Process Industries. It possesses all the design features essential for applications where safety is the prime consideration. The patented pumping action allows cool running to be achieved, thereby elongating seal life, whilst the double balanced design allows up to 30 bar (440 psi) product or barrier pressure to be accommodated.

first4seals plc, mount street, bradford, west yorkshire. bd3 9sn united kingdom
Tel: +44 (0) 1274 720775 Fax: +44 (0) 1274 729022
email: seals@first4seals.com - web: www.first4seals.com

Copyright © 2006 first4seals plc.
Reference Issue • 2LIT-GLEDBL/01 02/2006

first4seals™ and GLE are Trademarks of first4seals plc. 302™ is a Trademark of first4seals plc.
Atlas® - Asahi Glass Co., Chemraz® - Greene Tweed., Kalrez® - Viton® - DuPont Dow Elastomers.

GLE 302™

double mechanical cartridge seals

the green issue

The 302™ cartridge seal is designed with an external shroud and drain port for safe collection and removal of product and barrier fluid.

302™ cartridge seals can be fully refurbished with most parts being re-used.

As leakage is eliminated corrosion problems to pump, bearing and pump room are all greatly reduced.

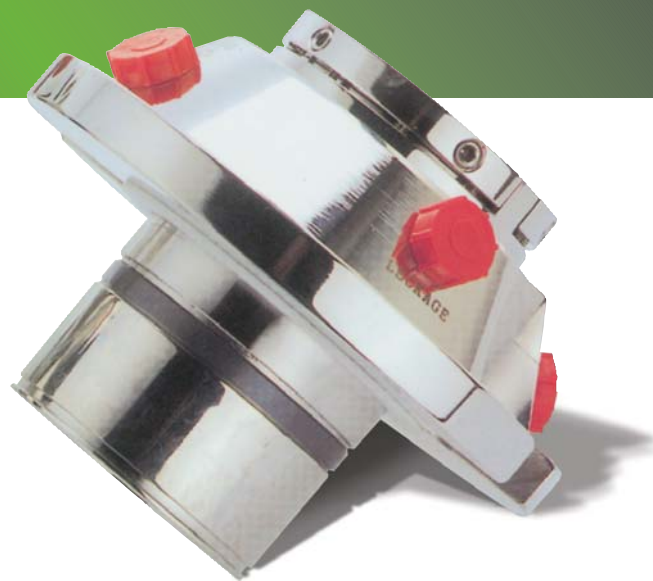

302™ series - technical specification

metal parts 316 Stainless Steel as standard. Alloy 276, Alloy 400, Alloy 20 also available.

springs Alloy 276

o-rings Viton® (Fluorocarbon) as standard. Ethylene Propylene, Kalrez®, Chemraz® and other elastomers available to order.

rotary face R-Carbon as standard, with A-Carbon, Tungsten Carbide, Silicon Carbide available.

stationary Silicon Carbide as standard. Tungsten Carbide and Ceramic also available.

temperature limits -30°C to 260°C (-22°F to 500°F) dependent upon specified elastomer and system configuration.

pressure limits - media and barrier

711mm HG Vacuum to 30 Bar (-28" HG - 440 PSI).
It is recommended that the barrier pressure is 1 Bar (15 psi) greater than the media.

As the conditions of use are outside the control of first4seals the information contained within this brochure is given in good faith but without warranty. The above temperature and pressure limits are individual maximum values for SOFT/HARD seal face combinations only. The values are provided for guidance only and are intended for use by suitably qualified application engineers. It is recommended that all users contact the first4seals Technical Department for advice on any new application.

302™ - design features

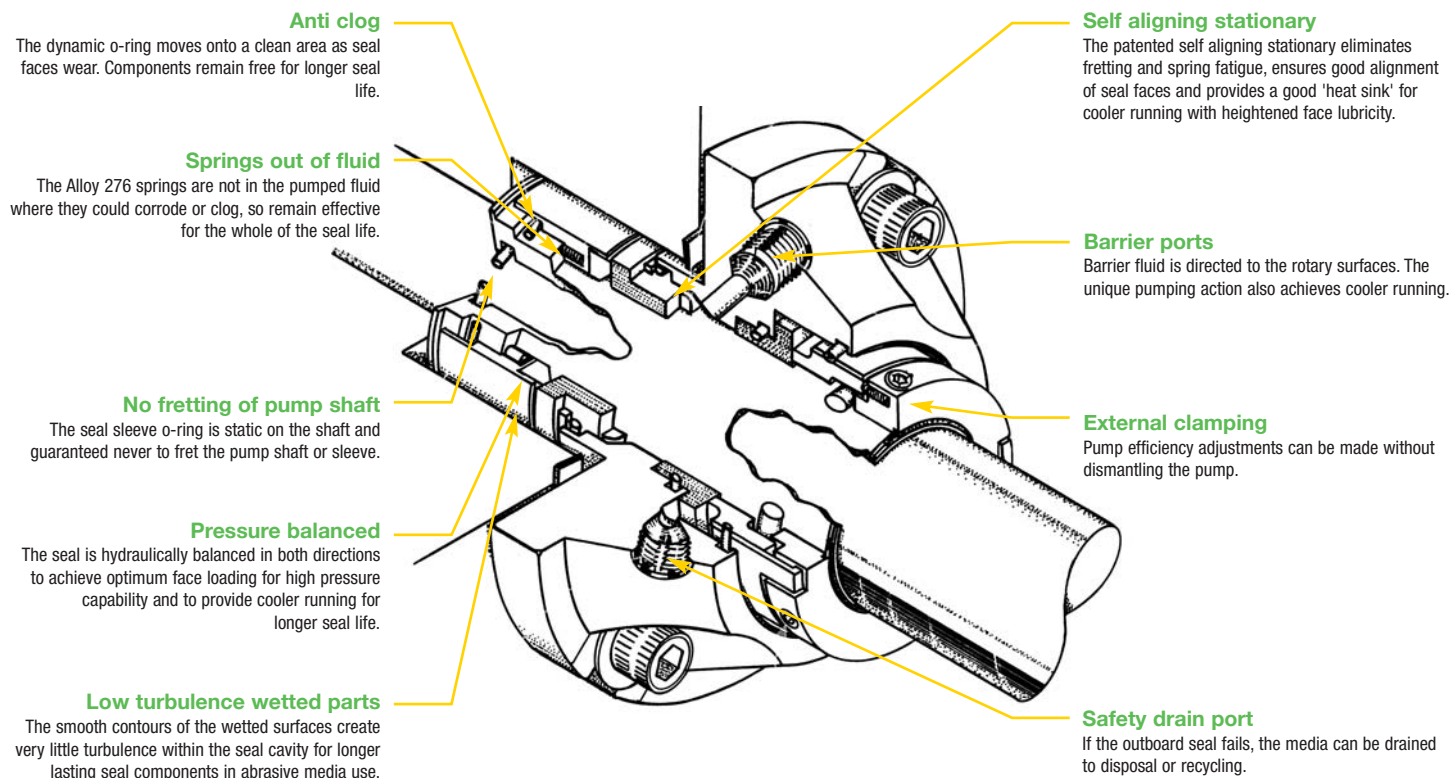

GLE 302™

dimensional information

Fixings available in 2 or 4 bolt.

Supplied with 2 barrier fluid ports and a safety drain port (1/4" BSP)

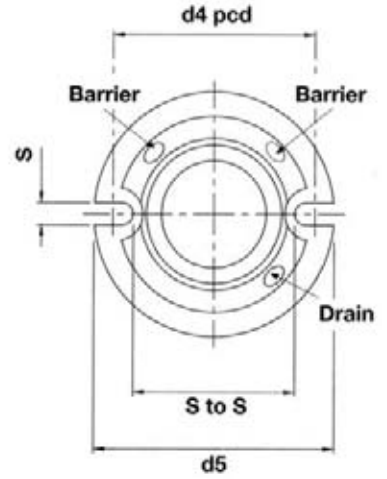
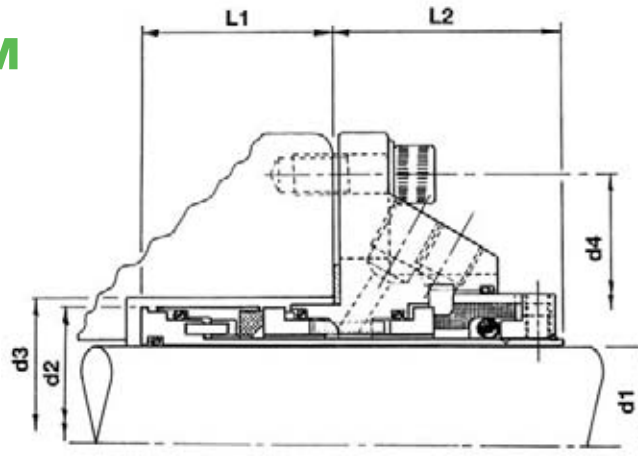

302™ series - size chart

d1		d2	d3	d4*pcd		d5	L1	L2	S to S	S
Imp.#	Met.	Rotary O.D.	S/B I.D.	Min	Max	Gland O.D.	Inboard	Outboard	Slot to Slot	Slot Width
1	25	42.6	44.5	69	82	95	44	51	59	12.7
1 1/8	28	45.7	47.6	72	85	100	44	51	62	12.7
1 1/4	30-33	48.9	50.8	75	90	105	44	51	65	12.7
1 3/8	35	52.8	54.0	78	95	110	44	51	68	12.7
1 1/2	38	56.0	57.2	85	100	120	46	54	73	15.9
1 5/8	40	59.2	60.3	88	100	120	46	54	76	15.9
1 3/4	43-45	62.4	63.5	91	115	135	46	54	79	15.9
1 7/8	48	65.5	66.7	95	115	135	46	54	83	15.9
2	50	68.7	69.9	98	130	150	46	54	86	15.9
2 1/8	53	71.9	73.0	101	130	150	46	54	89	15.9
2 1/4	55	75.1	76.2	104	145	165	46	54	92	15.9
2 3/8	60	78.2	79.4	107	145	165	46	54	95	15.9
2 1/2	-	84.2	85.7	127	150	175	52	60	111	17.5
2 5/8	65	87.4	88.9	130	150	175	52	60	114	17.5
2 3/4	70	90.5	92.0	134	150	175	52	60	118	17.5
2 7/8	-	93.7	95.2	137	165	190	52	60	121	17.5
3	75	96.9	98.4	140	165	190	52	60	124	17.5
3 1/8	80	100.0	101.5	143	165	190	52	60	127	17.5
3 1/4	-	103.2	104.7	149	175	200	52	60	130	20.6
3 3/8	85	106.4	107.9	152	175	200	52	60	133	20.6
3 1/2	-	109.6	111.1	156	175	200	52	60	137	20.6
3 5/8	90	112.8	114.3	159	196	215	52	60	140	20.6
3 3/4	95	116.0	117.5	162	196	215	52	60	143	20.6
3 7/8	-	119.1	120.6	165	196	215	52	60	146	20.6
4	100	125.5	130.0	181	211	230	55	66	162	20.6
4 1/8	105	128.6	133.0	181	211	230	55	66	162	20.6
4 1/4	-	131.8	136.5	181	211	230	55	66	162	20.6
4 3/8	110	135.0	139.7	190	221	240	55	66	171	20.6
4 1/2	115	138.2	142.9	190	221	240	55	66	171	20.6
4 5/8	-	141.3	146.1	190	221	240	55	66	171	20.6
4 3/4	120	144.5	149.2	200	231	250	55	66	181	20.6
4 7/8	-	147.7	152.4	200	231	250	55	66	181	20.6
5	125	150.8	155.6	200	231	250	55	66	181	20.6

All dimensions in (mm) except #

* Based on the largest bolt diameter (specials can be produced).

other seals in the GLE range: single cartridge seals and PCP cartridge seals

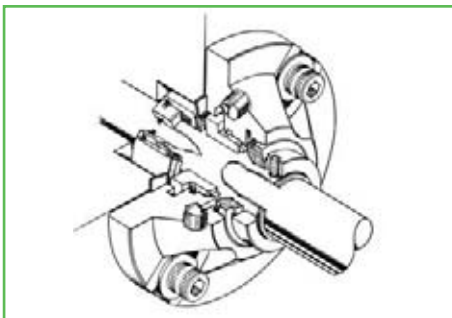

301™ range

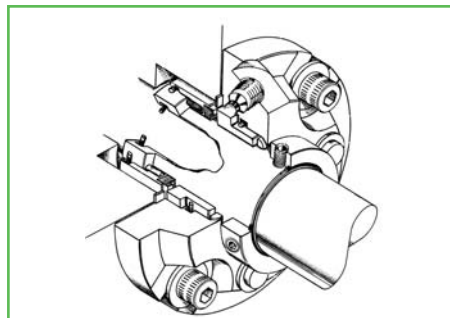

303™ range



PCP range

A range of single cartridge seals are available with Flush, Quench and Drain to suit all application needs. Seals to suit progressive cavity pumps (PCP) are also available in single and double formats. See the GLE single seal literature for further details.