

Installation Instructions

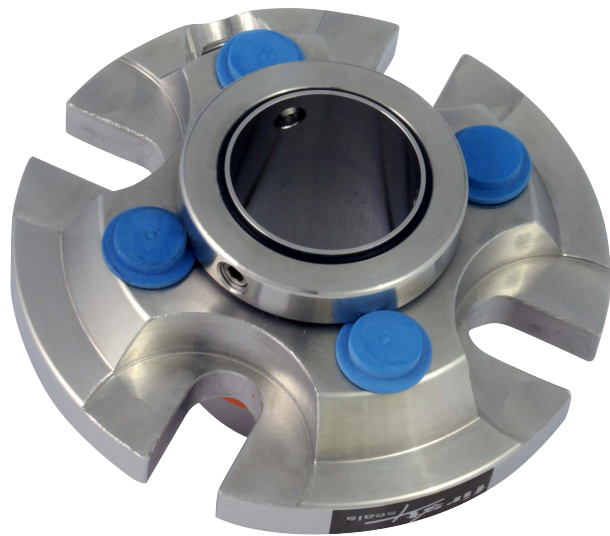

303A™

AESSEAL Marine plc, Unit 4 Venlo Industrial Estate, Knowles Street, Bradford, West Yorkshire, BD4 6HA, UK

Tel: +44 (0) 1274 720775 Fax: +44 (0) 1274 729022

Email: seals@first4seals.com - Web: www.first4seals.com

Copyright © 2019 AESSEAL Marine plc - Reference Issue • 2INST-303A-05



WARNING

Extreme care must be taken to ensure safe operation of equipment.
If in doubt seek expert advice. For Technical Support:
Email: technical@first4seals.com Telephone: +44 (0)1274 720775.

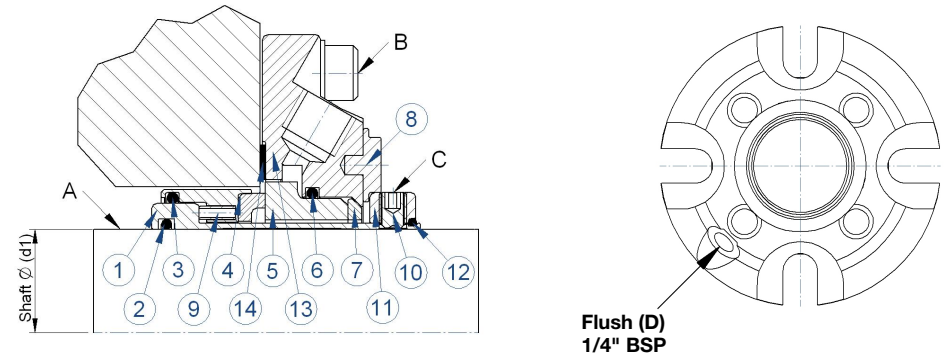

ITEM	DESCRIPTION
1	SLEEVE
2	STATIC O-RING
3	DYNAMIC O-RING
4	OUTER BARREL ASSY
5	STATIONARY FACE
6	STATIONARY O-RING
7	ALIGNMENT RING

ITEM	DESCRIPTION
8	CENTRING CLIPS
9	SPRING
10	DRIVE SCREWS
11	CLAMP RING
12	CLAMP RING O-RING
13	GLAND
14	GASKET

Pre-Installation:

- ✓ Check shaft diameter (d1) is in tolerance: Imperial Shafts +/- 0.002"
Metric Shafts +0 / -0.05mm
- ✓ Check shaft run out is in tolerance: <0.005" (0.13mm).
- ✓ Check shaft end float is in tolerance: <0.005" (0.13mm).
- ✓ Check stuffing box face finish to ensure suitable for creating a fluid seal.
- ✓ Check shaft (ref. A) for sharp edges to ensure no damage to secondary seal during installation.

Installation:

- ✓ Disassemble equipment to allow seal location on shaft.
- ✓ Apply suitable lubricant to shaft.
- ✓ Push seal on to shaft using the sleeve rather than gland.
- ✓ Re-assemble equipment into operational position.
- ✓ Affix seal to mounting with appropriate fixings & washers (Not included) and finger tighten (ref. B not shown).
- ✓ Tighten ALL fixing screws (ref. C) onto shaft equally.
- ✓ Tighten seal mounting fixings down firmly (ref. B, not shown) ensuring the gland is not moved off centre.
- ✓ Do not remove setting clips.
- ✓ Check for shaft binding or rubbing by rotating the shaft slowly by hand.
- ✓ If fouling occurs, remove the seal, check shaft and start installation again.
- ✓ If problem persists contact first4seals.
- ✓ Connect the Flush (ref. D). Ensure the port is plugged if not required.
- ✓ Ensure the pump is primed before operation.

DECLARATION OF INCORPORATION

This mechanical seal must not be put into service until the relevant machinery into which it is incorporated has been declared to be in conformity with the provisions of the Machinery Directive.